

Coil Dispenser

Effective 05-01-17

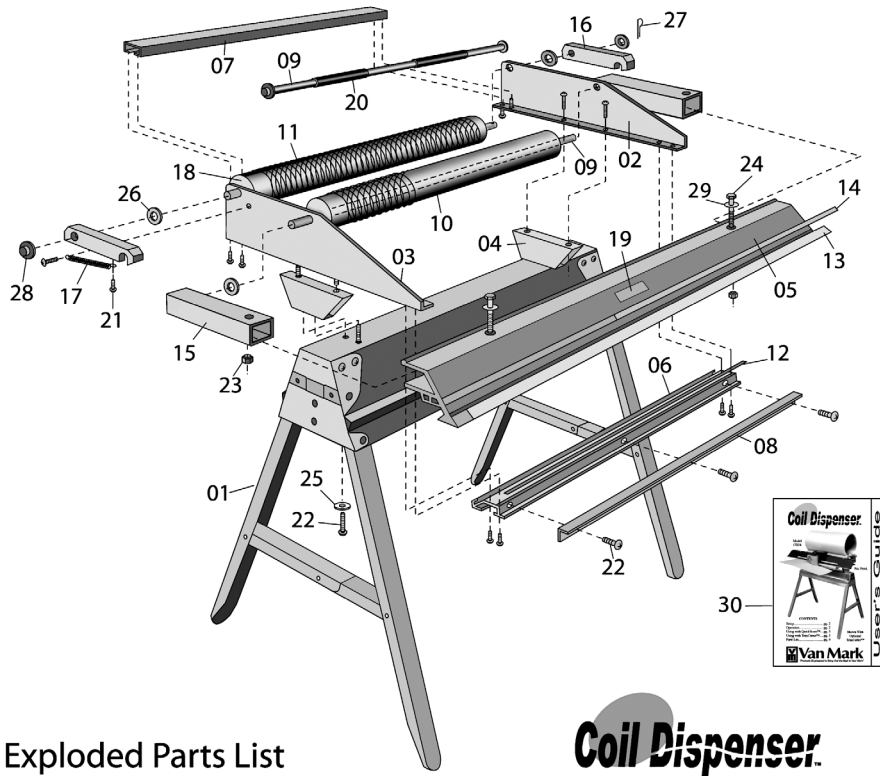

Exploded Parts List

Coil Dispenser

Ref	Description	Part No	Qty Req	Ref	Description	Part No	Qty Req
01	Folding Base	5405	1	16	Roller Arm	6543	2
02	Right Frame	6500	1	17	Spring	6544	2
03	Left Frame	6501	1	18	Bearing	4604	4
04	Mount. Block	6547	2	19	Nameplate	6552	1
05	Score Guide	6555	1	20	Foam Grip	4014	2
06	Scoring Bed	6506	1	21	Scrw 10-24x1/2	2005	4
07	Rear Rail	6509	1	22	Scrw 1/4-20x5/8	2033	23
08	Angle Support	6553	1	23	Nylok Hex Nut	2311	2
09	Axle	6518	3	24	Scrw 5/16-24x2 1/4	2057	2
10	Roller	6521	2	25	Wash 1/4 in. Flat	2510	4
11	Roller Cover	6524	2	26	Wash 1/2 in. Flat	2509	5
12	Vinyl Strip	6527	2	27	Cotter Pin	2700	1
13	Stainless Edge	6556	1	28	Palnut 1/2	2708	3
14	Tape Rule	6533	1	29	5/16 Flat Washer	2505	2
15	Pivot Arm	6551	2	30	User Guide	F545	1



Model CD24
Shown
With Optional
TrimCutter™

CONTENTS

Setup..... pg. 2
 Operation..... pg. 2
 Using with QuickScore™ pg. 3
 Using with TrimCutter™ pg. 3
 Parts List..... pg. 4

Products and specifications subject to change at any time.

24145 Industrial Park Dr., Farmington Hills, MI 48335

Toll Free No. 1-800-Van Mark Toll Free Fax 1-888-Van Mark
 Phone No. 1-248-478-1200 Area Fax No. 1-248-478-1226

Web site: www.van-mark.com E-Mail sales@van-mark.com



Van Mark
The Mark of Quality

User's Guide

Setup Instructions

- Unpack contents of boxes and lay out for assembly.
- Extend legs from stand and secure in outward position by pushing *down* on cross members (see diagram 1).
- Locate mounting blocks and install to underside of each frame as shown in diagram 2 using screw no. 22 (see parts list). Be sure to note hole alignment which is offset toward center of unit).
- Align remaining holes in bottom of mounting blocks with holes on stand. Insert washer no. 25 on screw no. 22 and install through bottom of stand and into bottom of mounting blocks.

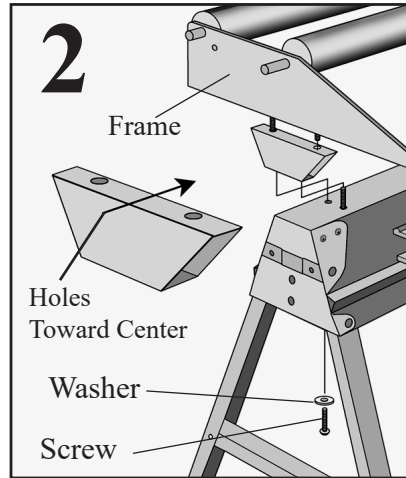
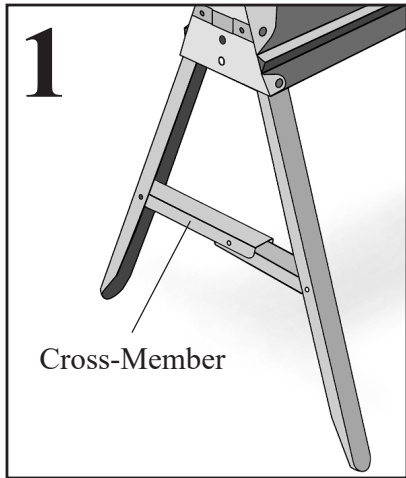

Operation

- Remove center axel and place coil onto bottom rollers. Replace center axel to prevent unraveling (see diagram 3).
- Feed coil between bottom rollers and also between the score guide and scoring bed.
- Place unit approximately 18 inches from brake (see below).
- Pull coil through brake to desired length. Score or cut and separate coil.

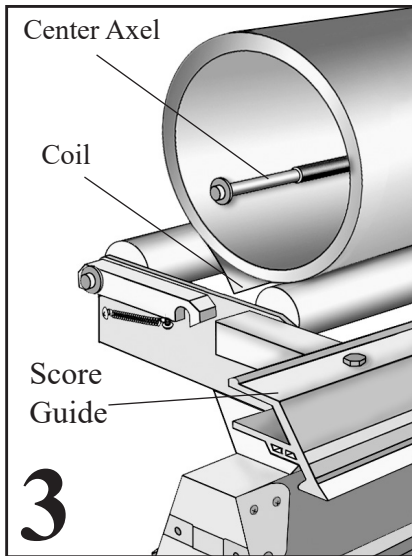

Note: As seen to the left, center coil with brake opening and allow material to pass freely through the brake without hitting castings.

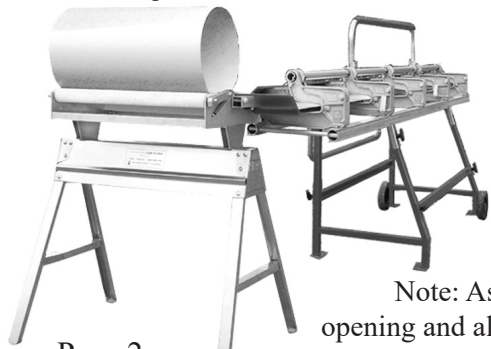

Using Optional QuickScore™

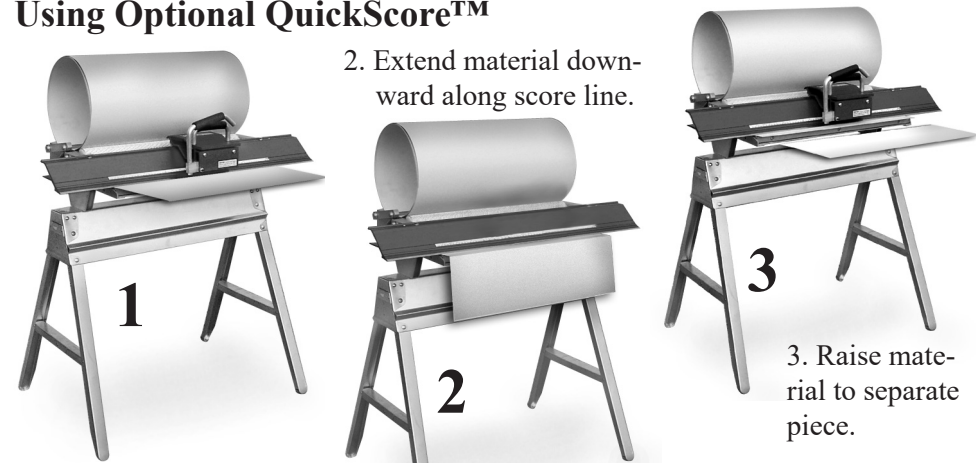

- Raise score guide and extend material through to desired length. Lower score guide against material. Engage blade against material and extend QuickScore™ along entire length of material. Set tool aside.



Model
3016

- Raise material to separate piece.

Note: When using Coil Dispenser™ and QuickScore™ with a brake, allow adequate spacing to flex material along score line.

Using Optional TrimCutter™

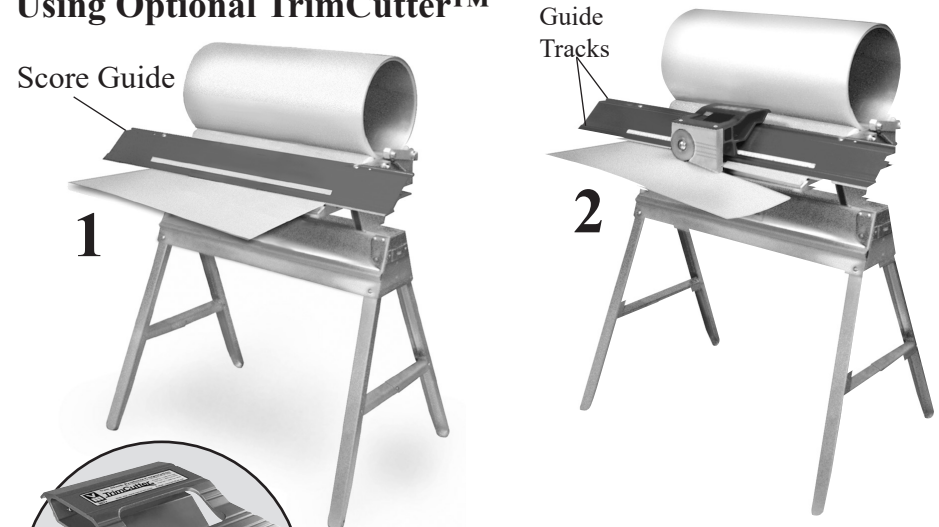

Model
3017

- Raise score guide and extend material through to desired length. Lower score guide against material.
- Place TrimCutter™ onto guide tracks. With one constant motion, extend TrimCutter™ along entire width of material until severed from coil. Remove tool when not in use.